



PROCESS ANALYSERS

# SmartDiver

## MUD DIVER

Level measurement and tank profiling system for thickeners, clarifiers, washers and CCD's to 110 deg C



- Precise measurement of clarity, interface depth and mud height. Plus tank profile (Depth vs Solids)
- Accurate and repeatable measurements derived from the self compensating measurement system.
- Built rugged to meet the requirements of the mineral processing industry.
- Remote communications and data logging standard.

Precision Light & Air Pty Ltd  
ABN 32 079 006 947

PO Box 73  
Seaford, Victoria 3198  
Australia

Telephone +61 3 9786 1711  
Facsimile +61 3 9786 1722  
Email [sales@plapl.com.au](mailto:sales@plapl.com.au)  
[www.plapl.com.au](http://www.plapl.com.au)



PROCESS ANALYSERS

## Level Measurement & Analyser System Smart Diver Compact & Smart Diver 'Duo'

### A Seriously Rugged Measurement System for a Seriously Rugged Industry

**Mineral Processing plants are usually not found in the shadows of cities. PL&A have always met our customers' demands in providing rugged and reliable equipment that will stand up to the rigours of their process and the harsh remote environments they are located in. The SmartDiver follows this tradition of ruggedness and high reliability.**

**Extensive design and engineering has brought to the market a serious and flexible industrial instrument that works continuously in your environment, not just in a laboratory.**

*"The SmartDiver follows this tradition of ruggedness and high reliability. "*

*"Ultrasonic technology has been discarded by PLA for the SmartDiver making way for a cheaper, newer, more robust sensor technology. "*



SmartDiver is a ruggedised mud diver that provides measurements of mud levels, settling zones and overflow clarity in thickeners/clarifiers and washers / decanters. Tank profiling (Suspended solids Vs depth) is also provided. Process engineers armed with this kind of data can attack process optimisation of flocculation and underflow density control head-on. Operations can almost cease manual "bombing" of the tanks and get detailed analysis of what is flowing in and out of their tankage.

Ultrasonic technology has been discarded by PLA for the SmartDiver making way for a cheaper, newer, more robust sensor technology.

SmartDiver has purposely been designed around easy to access non-proprietary components to ensure easy and long term maintainability even in the most remote locations. Remote GSM dial-in communications helps here and is supplied standard with almost everything in the PLA range.

Rather than needing to compromise low-end clarity measurement accuracy with high-end heavy mud rangeability, PLA have introduced the SmartDiver Duo, 2-probe design offering a clarity and a heavy mud probe in the one device. Simply, you cannot get a single probe to be accurate to 10 mg/litre for a nice repeatable clarity measurement and expect

the same probe to dive down and measure heavy mud to 300 grams per litre. So we use two probes. As a bonus, there is then some cross over in measurements which gives you some redundancy.

Special attention has been given to the traditional high maintenance mechanical systems associated with retracting level measurement systems. As an example, cabling connecting the SmartDiver sensors is specifically designed for continuous winding applications and more commonly found in heavy duty applications in elevator control and off shore winching applications. A 40mm solid stainless steel shaft on stainless steel bearings might sound like overkill but divers installed 5 years or more ago are still rolling with next to no maintenance.

The on-board PLC ensures that the SmartDiver can functionally do almost anything you want. You think it, we write the code and load it and test it. You can take a standard monochrome Panel view with fault logging and a few keys to enter and view data, or opt up for a colour touch screen with trending and live multi-dive tank profiling. Later down the track, your own E/I techs can add functionality without PLA involvement. The diver can evolve or devolve as your demands change.

# SmartDiver

Designed for the Minerals Industry.  
Rugged, Low-Maintenance, Accurate, Repeatable

Dimensions, SmartDiver Compact

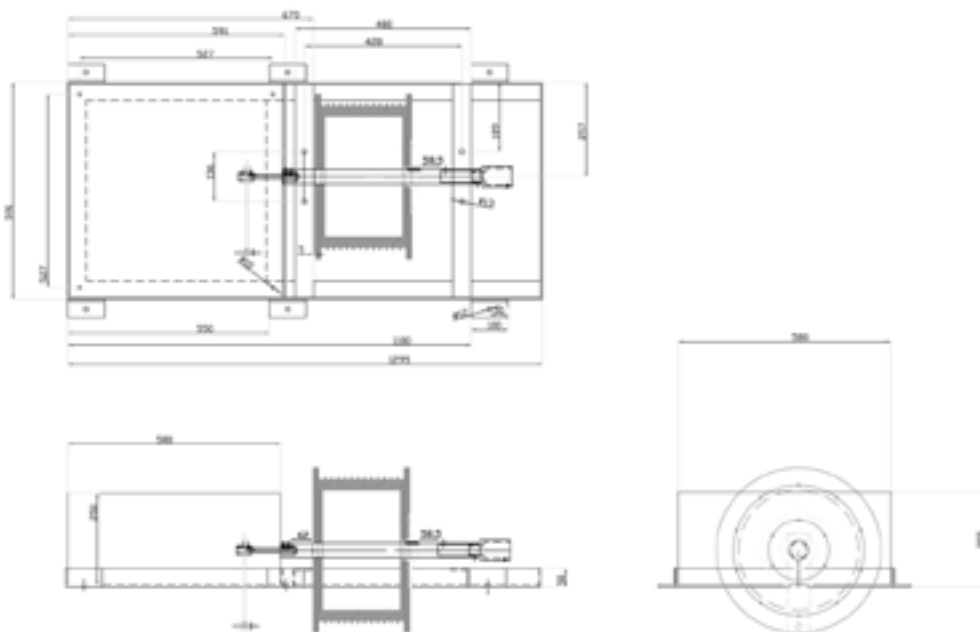

*“PLA have always met their customers demands in providing rugged and reliable equipment. ”*

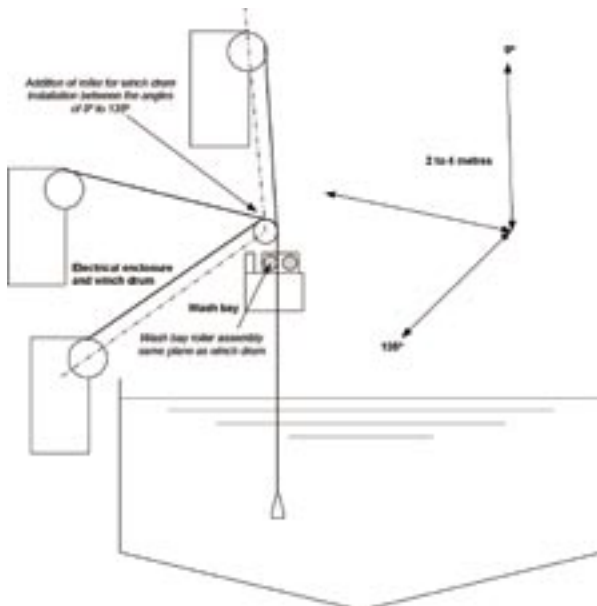

*“Rather than needing to compromise low-end clarity measurement accuracy with high-end heavy mud rangeability, PLA have introduced SmartDiver Duo. ”*



PROCESS ANALYSERS

## Specifications

- **Maximum Process Temperature:** Std: 85 deg C  
Opt: 110 deg C
- **Outputs:** Analog: 4x 4-20mA  
Digital: ModBus, DH+, RS485 & Ethernet/IP
- **Clarity:** Accuracy +/- 2% of reading  
Repeatibility +/- 1% of reading
- **Level:** +/- 5-10mm (dependant on rake speed)
- **Power Supply:** 240/110 Vac or 24 Vdc

## Model Coding

- **Single Probe System (SmartDiver Compact)**  
Stand-alone AL-6410  
PLC/DCS interface and support AL-6420
- **Multi-Probe System (SmartDiver Duo)**  
Stand-alone AL-6412  
PLC/DCS interface and support AL-6422

## Ordering Information

- Process liquid
- Measurement Parameters Required
- Process Temperature (normal, maximum)
- Total Height (mounting point to tank base - mm)
- Rake Rotation Speed
- Power Supply
- Stand-alone (AL-6410) or PLC/DCS interface (AL-6420)

## PLA's Other Products

- Liquor Density Refractometer to 200 deg C
- In-line Ceramic Conductivity Sensor to 280 deg C
- Clarity Probes (Turbidity Probes)
- Liner-Free Magnetic Flowmeters

## Products Under Development

- Clarity Meter (settling rate analyser)
- Opus Particle size analyser
- Ultrasonic Slurry Density Meter
- pH for Slurries.

**Precision Light & Air Pty Ltd**  
ABN 32 079 006 947  
**PO Box 73**  
**Seaford, Victoria 3198**  
**Australia**  
**Telephone +61 3 9786 1711**  
**Facsimile +61 3 9786 1722**  
**Email sales@plapl.com.au**  
**www.plapl.com.au**